

## **Configuring a Classroom for Hybrid In-Person/Distance Learning**

Jim McClure

Betsy's Folly Studios, LLC

*Revision 1.4*

*8/6/2020*

### **Overview**

The SARS-CoV2 pandemic has upended all aspects of life, but perhaps especially K-12 education. Schools are being forced to consider options for in-class and remote participation to a degree never attempted before.

This document describes requirements and potential approaches for configuring a typical physical classroom for hybrid in-person/distance learning at the elementary and high-school level. The idea is to understand how to take a “traditional” classroom space and make it work in the hybrid environment. The focus is not on creating an “ideal” experience, but rather on creating a reasonably practical configuration using currently available technology that can be applied without requiring schools to rebuild every classroom and turn them into media centers.

In the context of this paper, the “hybrid” approach consists of a classroom and an instructor with one or more students physically present, and one or more students attending virtually over the Internet. We will assume for the purposes of this discussion that the students and instructors are using laptop computers and other devices with remote access software such as Google Meetings, Zoom, etc.

### **Requirements**

To provide a workable experience for the remote learners, the following requirements would appear to be necessary:

1. Basic
  - a. The remote students must be able to clearly hear the spoken voice of the instructor. This must be the case even as the instructor moves about the classroom.
  - b. The remote students must be able to see, at a minimum, the instructor and any teaching materials or surfaces (blackboards, etc.).
  - c. The remote students must be able to speak to the instructor to ask and answer questions.
  - d. The instructor must be able to hear the remote students when they are speaking.
  - e. The instructor must not be prevented from seeing and hearing the physically present students in the normal way.
  - f. The instructor must be able to move about the classroom in a reasonably normal way; they cannot be “tethered” to one particular spot in the classroom.
  - g. The equipment used to satisfy these requirements must be reasonably portable, so that a variety of classroom spaces can be used.
2. Enhanced
  - a. The remote students should have the option to hear the physically present students for situations where there is a group discussion. They will need to be able to control this

function so as to be able to focus on the instructor and block out classroom noise as appropriate.

- b. The physically present students should have the ability to hear the remote students when they are speaking. The instructor will need to be able to control this feature to block out noise from the remote students as appropriate.
- c. The remote students should be able to see the students that are physically present in the classroom, in addition to seeing the instructor and learning materials or surfaces.
- d. The students physically present in the classroom should be able to see the remote students.

### **Audio Requirements**

Although discussions of remote access to meetings or classrooms frequently focus on being able to *see* the participants (e.g., through video), less thought is often given to the necessity of there being *clear audio* so that the speakers are easily intelligible. In actuality, clearly intelligible speech is much more important than the visual presentation.

When spoken voices are marginally intelligible, additional cognitive resources must be devoted to “decoding” the speech. These same cognitive resources are also used for analysis and comprehension in a learning environment. Thus, when a remote learner is forced to struggle to decode marginally intelligible speech, he or she has *less available cognitive resources to learn*.

For intelligible speech, a typical microphone should be located between 6 and 12 inches from the speaker’s lips. *Note that this is quite a short distance*. As the microphone is placed farther away from the speaker’s mouth, room reflections and noise make up an increasing proportion of the captured sound. (See Figure 1.) These reflections and noises “muddy” the spoken voice to the point that decoding the speech is no longer “effortless.” The listener is forced to divert cognitive resources from comprehension and analysis of the subject material to the purpose of decoding the speech.

Figure 1. (From El Paso Media Fest 2020 Conference Presentation)

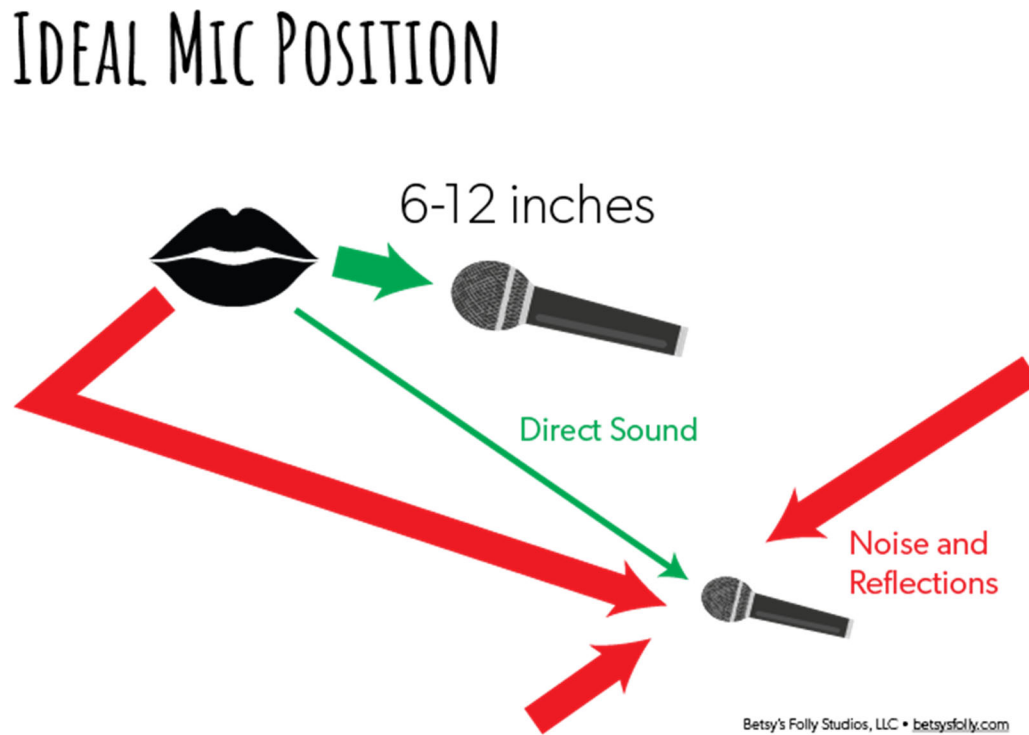

## Audio Design: Transmitting To Remote Students

For an instructor moving about a classroom, the requirement for clear audio for remote learners dictates the use of a portable microphone. Common portable microphones usable in this situation include *lavalier* microphones (which are commonly used in film and television) and *headset* microphones (which are often used in exercise classes and conferences). *Bluetooth* devices also have a built-in microphone and are typically of the headset or in-ear design.

Headset microphones are often quite visible (i.e., the boom may come down from the ear to the mouth) and may be distracting to the in-class participants. Bluetooth earpieces are relatively inconspicuous. Lavalier microphones are the least conspicuous of all, as they can be hidden in the chest area in a shirt or dress.

In terms of number of required components, a Bluetooth headset is the simplest choice. Unfortunately, there are several disadvantages to this approach:

1. Bluetooth headsets come with an earpiece that blocks one ear. This may or may not be comfortable for the instructor as they try to listen to the remote students and the in-class participants at the same time.

2. On most computers there is no way to route the voices of the remote students to *both* the in-ear Bluetooth device and a set of speakers<sup>1</sup>. For that reason, only the instructor will be able to hear the remote students; the in-class participants will not be able to hear the questions or replies of the remote students unless the teacher repeats them.
3. Bluetooth devices have small internal batteries that need to be charged by plugging the unit into a USB power source; this is an extra maintenance step.
4. Bluetooth devices are not particularly foolproof; they can lose their “pairing” with the host computer and have a decrease in effective range as their battery declines.

### **Audio Design: Listening To The Remote Students**

To meet any or all of the “Enhanced” requirements, a solution other than the Bluetooth headset will be required because the Bluetooth headset will not allow students in class to follow along with the remote students’ comments and questions<sup>2</sup>.

A solution that would address this problem is shown in Figure 2. This example shows the use of a wireless lavalier microphone that transmits its sound back to a receiver. The receiver is plugged into a small audio interface which is connected to the computer by a USB cable.

---

<sup>1</sup> The author has tested this possibility under quite a few different configurations, with and without third party software. Later versions of Mac O/S seem to offer a slight advantage to accomplishing this goal.

<sup>2</sup> See Appendix A for a possible solution using new technology.

**Figure 2. Lavalier Mic Configuration**

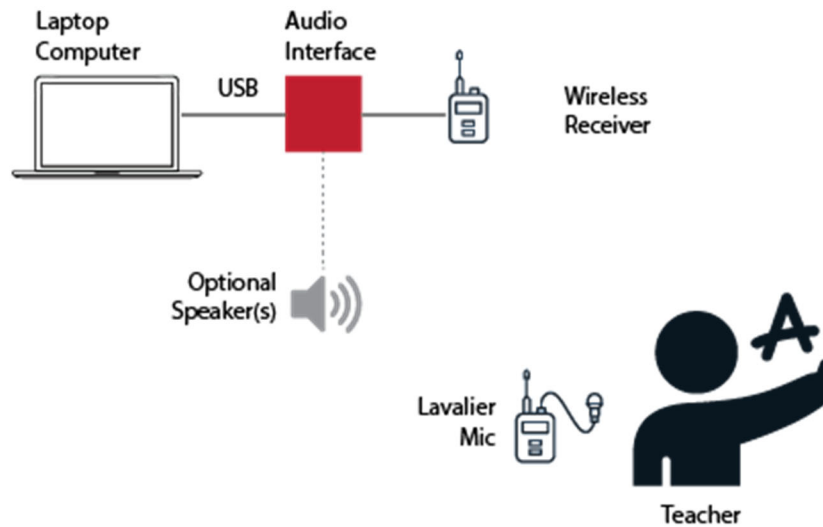

There are two possibilities for speakers: The computer can simply be set up to use its internal speakers, or an external speaker (or pair of speakers) can be connected to the audio interface with a standard cable. (Note that some laptops do not have very loud speakers; in those cases, an external speaker would be advisable.)

The advantages of this approach are:

1. There is no earpiece in the instructor's ear so their ability to hear the in-class participants is unobstructed.
2. The lavalier microphone is virtually invisible and therefore unobtrusive.
3. Both the instructor and the in-class participants can hear the remote students.
4. Wireless lavalier microphone sets are generally more robust than Bluetooth units and have a much more generous range.
5. Rechargeable batteries of a standard size (usually AA) can be used and are easily replaced in the event of failure.

Disadvantages are:

1. More components.
2. Higher cost depending on what options are selected.

Another approach to the same architecture is shown in Figure 3. In this figure, the wireless lavalier microphone transmits back to a USB receiver. We have tested only one unit (there are only a few units with a USB receiver) but it seems to work well and is simpler and less costly than Figure 2. (See Appendix B.)

**Figure 3. Lavalier Mic Configuration**

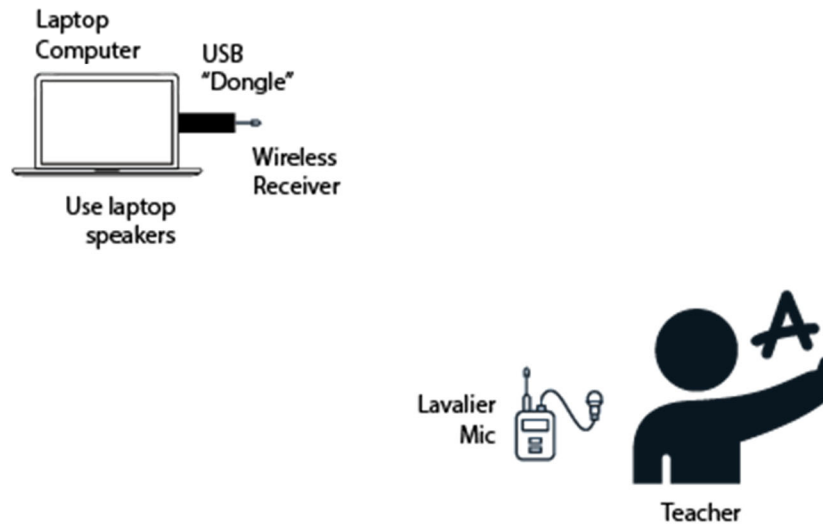

This configuration eliminates the external audio interface component and reduces cost and complexity. However, this depends on the laptop speakers being loud enough to broadcast to the whole class. If external speakers are needed, it will generally be easier to go with the configuration shown in Figure 2, as inexpensive (i.e., non-Bluetooth) external speakers can be easily plugged in to the interface.

### **Meeting All Enhanced Requirements**

Meeting all of the enhanced requirements is probably not feasible with a portable system. Additional microphones, cameras, screens, etc. would likely be needed, as well as some adaptations to the meeting software. For this reason, a design adhering to those requirements is not attempted here.

## **Appendix A: Bluetooth 5**

A possible new solution to Requirement 2.b. (allowing in-class participants to hear remote students) could be Bluetooth 5, which advertises that it can send to two Bluetooth destinations at once.

Since this is such a new standard, it is unlikely that many existing laptops would support it. There are Bluetooth 5 “dongles” that can be purchased. These would need to be tested for compatibility with each laptop.

With the Bluetooth 5 “dongle,” it should be possible to purchase a Bluetooth Speaker and direct the remote students’ audio to both the in-ear Bluetooth headset and the speaker. This would be a slightly simpler configuration than that shown in Figure 2, however it would still have the same drawbacks listed with the original Bluetooth configuration. Cost would likely fall between the simpler Bluetooth configuration and the wireless lavalier configuration. Note that we have not at present tested this approach.

## Appendix B: Parts Lists

The following are some suggested parts lists for the different configurations. Each of these sets of components have been successfully tested with Zoom and Google Meetings. Each configuration assumes a laptop computer with USB port(s).

An important consideration regarding the wireless mic sets is that **each teacher will need their own personal lavalier mic and transmitter**. Sharing the units would not be advisable as the mic will be placed close to the speaker's face and could transmit the virus.

All components are available from Amazon, B&H Photo Video (bhphotovideo.com), Sweetwater, and other retailers. Note that this list is by no means exhaustive; rather, the intention is to mention quality components that are also affordable. Approximate costs as of the date of this report are included for each component.

### Figure 2: External Audio Interface Parts List

This configuration is suitable for a larger classroom (i.e., more than a dozen physically distanced students) and offers greater distance and quality for the wireless mic. Total cost is approximately \$400.

#### *1 x Focusrite Solo USB Audio Interface (\$100)*

This is a reliable component from a well-known manufacturer that is plug-and-play in Windows and Mac systems with no complicated installation. It features 1 x XLR mic input for the wireless receiver and two 1/4" TRS outputs for external speakers.

#### *1 x Audio Technica PRO 88W-R35 VHF Lavalier Microphone System (\$150)*

Audio Technica is a reliable brand at a reasonable cost. This unit includes the belt transmitter, lavalier microphone, and the receiver (which plus into the Focusrite Solo XLR input). Both receiver and transmitter are powered by 9V batteries.

#### *1 x Watson 2-Bay 9V Charger and 4 x 9V Batteries (\$15 + \$32)*

Watson is a popular manufacturer of rechargeable batteries and chargers. We recommend 4 batteries so you can just swap pairs in and out of the transmitter and receiver.

#### *1 Pair Presonus Eris 25W Speakers (\$100)*

Presonus is a quality brand and these speakers will have good fidelity and be loud enough for a large classroom.

#### *1 x Hosa Technology Pro Dual 1/4" TRS Male-To-Male Stereo Audio Cable- 5-feet (\$14)*

Cable to connect speakers to Focusrite Audio Interface.



### **Figure 3: Wireless Lavalier Mic with USB Interface**

This is a lower-cost configuration suitable for a smaller classroom (a dozen or less of physically-distanced students). Total cost is about \$100.

#### *1 x FIFINE USB Wireless Microphone System for PC/MAC (\$57 from Amazon)*

This is a wireless lavalier microphone with belt transmitter and a USB receiver that plugs directly into the computer. We have tested this unit and found it to work surprisingly well considering the low cost. Obviously for the price, it is not a heavy-duty unit (the plastic is lightweight), so you may want to purchase a few backup units. The unit includes both a clip-on lavalier microphone for less-obtrusive use, and a headset microphone.

#### *1 x Watson 4 Hour Rapid Charger for AA/AAA Batteries & 4 x Watson AA Batteris (\$10 + \$9)*

Watson is a popular manufacturer of rechargeable batteries and chargers. The FIFINE unit uses 2 X AA batteries for the transmitter. We recommend 4 batteries so you can just swap pairs in and out of the transmitter.

#### *1 x Pair Logitech Z130 Speakers (\$20)*

Inexpensive but popular powered speakers for a smallish classroom. They plug in to your computer's audio output jack. If your classroom is medium-sized, you may want to look into more powerful speakers.

### **Alternatives**

There are not a lot of wireless lavalier systems with USB receivers, but the following is a just-released, alternative to the FIFINE system:

#### *1 x Samson XPD2 Lavalier USB Digital Wireless System (\$119)*

We have not tested this specific component, but Samson products are generally well built and cost-effective. It should offer greater range and reliability vs. the FIFINE unit. (Check battery type.)